

Lantech

IFR-0202

Universal Redundant Fiber Controller

User Manual



Ver.1.00
14-Feb-2011

FCC Warning

This Equipment has been tested and found to comply with the limits for a Class A digital device, pursuant to Part 15 of the FCC rules. These limits are designed to provide reasonable protection against harmful interference in a residential installation. This equipment generates, uses, and can radiate radio frequency energy. It may cause harmful interference to radio communications if the equipment is not installed and used in accordance with the instructions. However, there is no guarantee that interference will not occur in a particular installation. If this equipment does cause harmful interference to radio or television reception, which can be determined by turning the equipment off and on, the user is encouraged to try to correct the interference by one or more of the following measures:

- Reorient or relocate the receiving antenna.
- Increase the separation between the equipment and receiver.
- Connect the equipment into an outlet on a circuit different from that to which the receiver is connected.
- Consult the dealer or an experienced radio/TV technician for help.

CE Mark Warning

This is a class A product. In a domestic environment this product may cause radio interference in which case the user may be required to take adequate measures.

Content

| | |
|-------------------------------|----|
| FCC Warning | i |
| CE Mark Warning..... | i |
| Overview | 1 |
| Introduction..... | 1 |
| Features | 2 |
| Packing List | 2 |
| Safety Precaution | 2 |
| Hardware Description..... | 3 |
| Front Panel..... | 3 |
| Top View | 4 |
| Wiring the Power Inputs..... | 4 |
| LED Indicators | 6 |
| Mounting Installation | 7 |
| DIN-Rail Mounting | 7 |
| Wall Mounting..... | 9 |
| Fiber Cable Connection | 10 |
| Technical Specification | 10 |

Overview

Introduction

This user manual is suitable for the products as follows:

- Universal Redundant LC Fiber Controller
- Universal Redundant SC Fiber Controller
- Universal Redundant ST Fiber Controller

The Lantech IFR-0202 provides a permanent and trouble-free access port for in-line network devices. The fiber controller automatically switches network traffic through added in-line devices or bypasses devices that are about to be removed. Prevent link failure when attached in-line devices lose power by powering the IFR-0202 and in-line device from the same power source.

The Lantech IFR-0202 supports bypass function with fiber in-line device when it shares the same power source as the in-line device. While the IFR-0202 is receiving power, it diverts network traffic to attached in-line devices. In this state, all in-line traffic is routed directly to the device connected to the IFR-0202.

When the Optical Fiber Controller loses power, in-line traffic continues to flow through the network link, but is no longer routed through the device. This allows the network devices to be removed and replaced without network downtime. Once power is restored to the IFR-0202, network traffic is seamlessly diverted to the in-line device, allowing it to resume its critical functions.

Features

- Bypass function with fiber in-line device at speeds of 100 Mbps / 1000 Mbps / 10 Gbps
- Increased reliability on critical network links
- High-speed optical switching (<5ms) with minimal insertion loss (Max 1 6dB as Bypass Mode)
- Fully RoHS compliant
- IP 30 protection with DIN rail and wall mount design
- LED indicator shows power status
- Tested and compatible with all major manufacturers' in-line devices
- 30 Seconds Boot Up Delay Design

Packing List

- 1 x Universal Redundant Fiber Controller
- 1 x User Manual

Safety Precaution

Attention IF DC voltage is supplied by an external circuit, please use a protection device on the power supply input.

Hardware Description

In this paragraph, we will introduce the Universal redundant fiber controller's hardware spec, port, cabling information, and wiring installation.

Front Panel

The Front Panels of the Universal Redundant Fiber Controllers are shown as below.

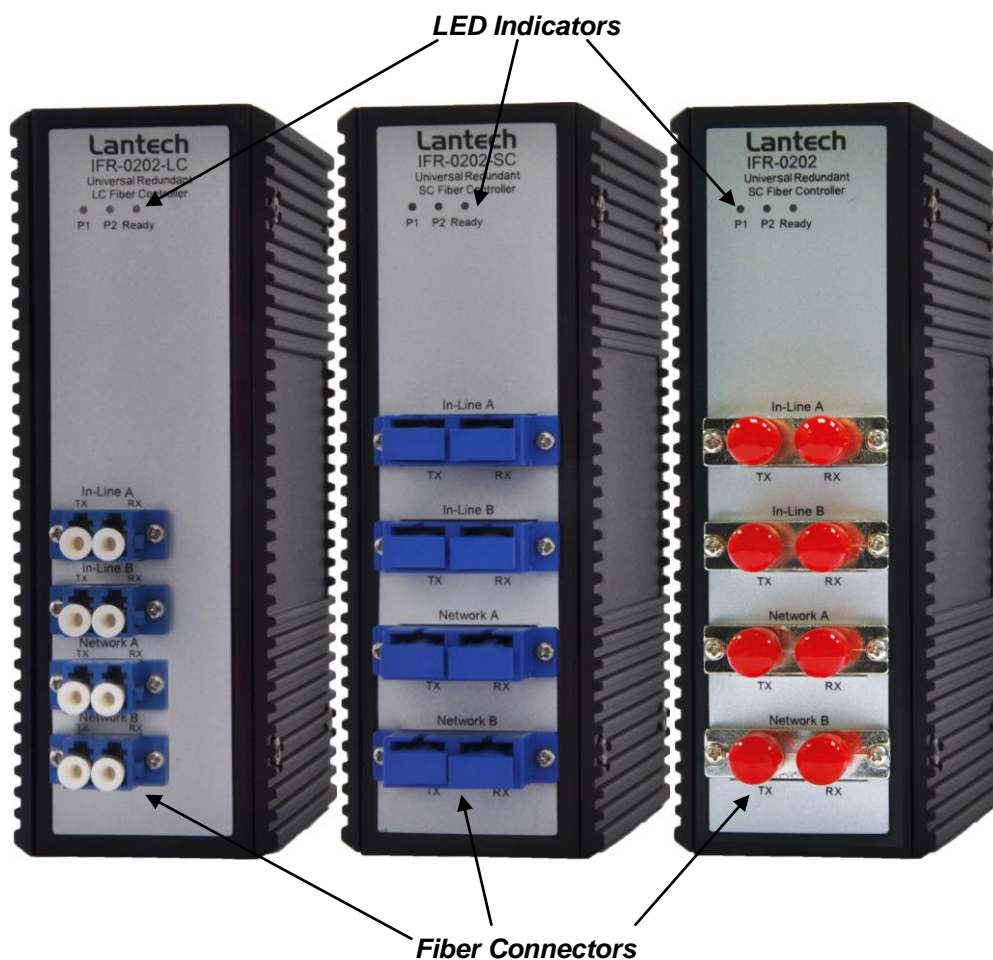

Front Panels of the Universal Redundant Fiber Controller

Top View

The top panel of the Universal Redundant Fiber Controller is equipped one terminal block connector of two power inputs.

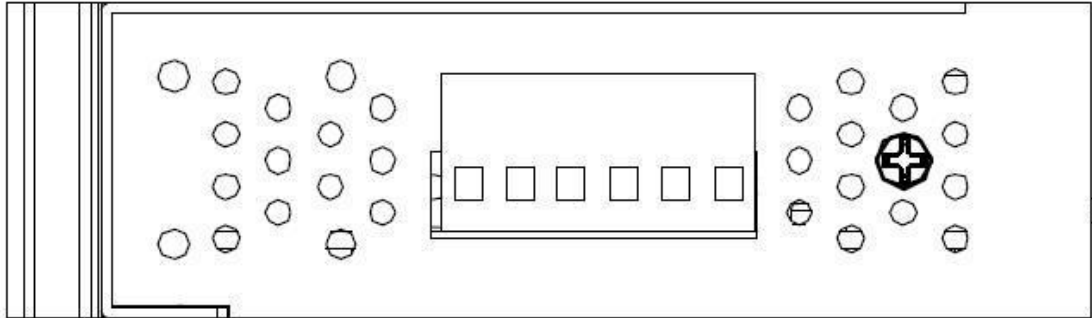

Top Panel of the Universal Redundant Fiber Controller

Wiring the Power Inputs

Please follow the steps below to insert the power wire.

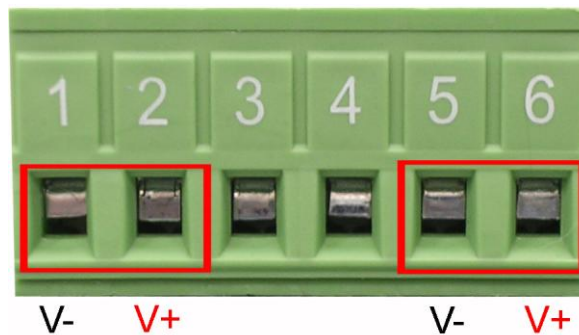

1. Insert the positive and negative wires into the V+ and V- contacts on the terminal block connector.

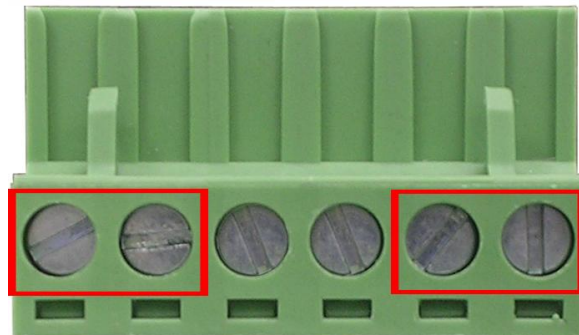

2. To tighten the wire-clamp screws for preventing the wires to loose.

Note *The wire gauge for the terminal block should be in the range
between 12~ 24 AWG.*

LED Indicators

There are few LEDs display the power status and network status located on the front panel of the universal redundant fiber controller, each of them has its own specific meaning as below table.

| LED | Color | Description | |
|-------|-------|-------------|--------------------------------|
| P1 | Green | On | Power input 1 is active |
| | | Off | Power input 1 is inactive |
| P2 | Green | On | Power input 2 is active |
| | | Off | Power input 2 is inactive |
| Ready | Green | On | The device is in normal status |
| | | Off | The device is in bypass status |

Mounting Installation

DIN-Rail Mounting

The DIN-Rail bracket is screwed on the device on the production line in the factory. If the bracket is not screwed on the controller, please refer to **Figure-1** to screw it on the device. Follow the steps below to hang the industrial device.

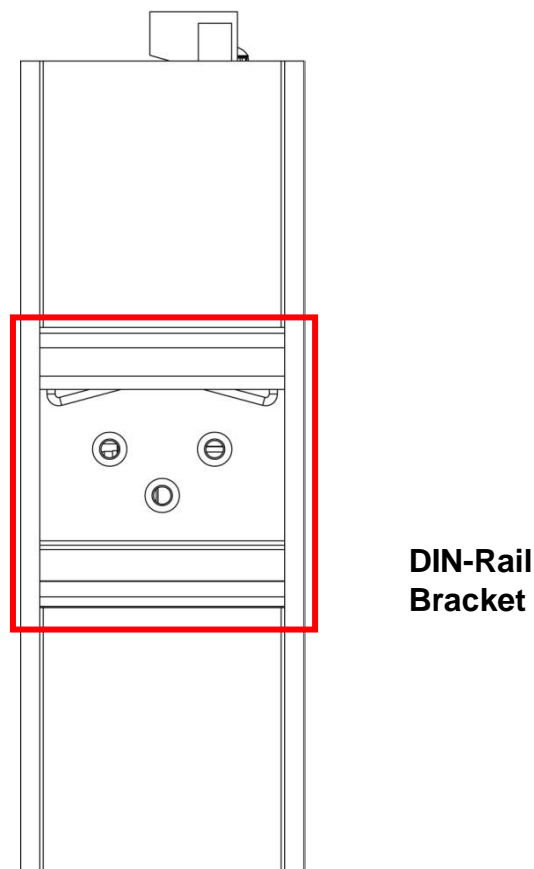

Figure-1: Rear side of the Universal Redundant Fiber Controller

1. Use the screws to screw the DIN-Rail bracket on the rear side of the device.
2. To remove the bracket, reverse the step 1.
3. After the DIN-Rail bracket is screwed on the rear side of the controller,

insert the top of the bracket into the rail as **Figure-2**.



Figure-2

4. Then, lightly pull-down the bracket into the rail as shown in **Figure-3**.



Figure-3

5. Check if the bracket is tightened on the rail or not.
6. To remove the controller from the rail, reverse steps above.

Wall Mounting

Please refer to **Figure-4** and follow the steps below to mount the universal redundant fiber controller with wall-mount bracket, and the detail dimension of the bracket as **Figure-5**.

1. Remove the DIN-Rail bracket from the device; loose the screws to remove it.
2. Place the wall-mount bracket on the top side and bottom side of the device.
3. Use the screws to screw the wall-mount bracket on the device.
4. Use the hook holes at the corners of the wall-mount bracket to hang the device on the wall.
5. To remove the wall-mount bracket, reverse steps above.



Figure-4: Wall-Mount Bracket Installation

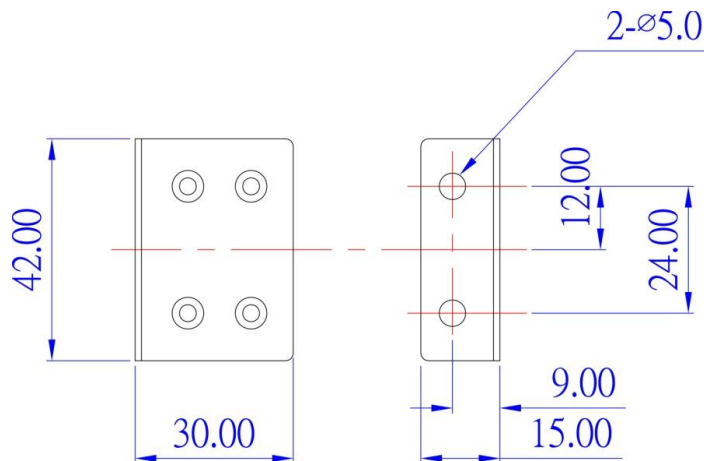
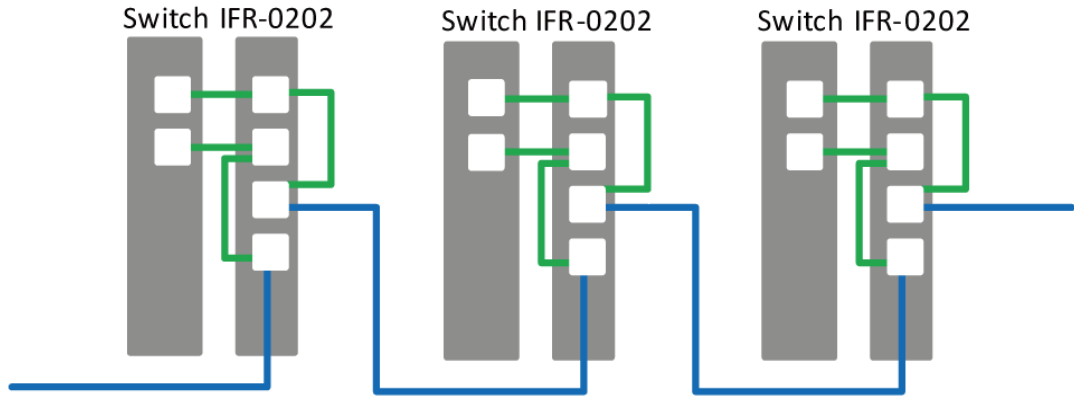

Figure-5: Wall-Mount Bracket Dimensions

Fiber Cable Connection

Please connect fiber cables between UFR-0202 and network device as the following figure.



Technical Specification

| | | | |
|--------------------------------------|--|------|------|
| Connector | LC or SC or ST Fiber Connectors | | |
| Optical Cable | Fiber Type: Multimode Corning 62.5/125 μ m, wavelength, 850nm Insertion Loss: Max 1.6dB when the switch losing power and is in Bypass mode Fiber Type: Singlemode Corning 9/125 μ m, wavelength, 1300~1550nm Insertion Loss: Max 1.6dB when the switch losing power and is in Bypass mode | | |
| Boot Up Delay | Every time the power has been connected, it'll take about 30 seconds delay then boot up. | | |
| Operation Wavelength | 1280-1340/ 1520-1625 nm | | |
| Insertion Loss (dB) 1310/ 1550 nm | TX1→A0 | 0.62 | 0.51 |
| | RX1→A1 | 0.55 | 0.43 |
| | TX2→B0 | 0.35 | 0.35 |
| | RX2→B1 | 0.81 | 0.66 |

| | | | |
|---|--|------------|------|
| | TX1→RX2 | 0.91 | 0.89 |
| | RX1→TX2 | 0.99 | 0.86 |
| Repeatability (peak to peak) 100 Cycles 1550 nm | ALL CH | Pass ≤ 0.1 | |
| Return Loss (dB) 1310/ 1550 nm | TX1→A0 | 50 | 53 |
| | RX1→A1 | 52 | 53 |
| | TX2→B0 | 52 | 53 |
| | RX2→B1 | 50 | 54 |
| | TX1→RX2 | 49 | 51 |
| | RX1→TX2 | 54 | 52 |
| PDL (dB) 1550 nm | ALL CH | Pass ≤ 0.1 | |
| WDL (dB) 1310/ 1550 nm | ALL CH | Pass ≤ 0.3 | |
| Switching Time (ms) 1550 nm | ALL CH | Pass ≤ 5 | |
| Cross Talk (dB) 1550 nm | ALL CH | Pass ≤ -80 | |
| LED | Power (Green) | | |
| Operating Humidity | 5% ~ 95% (Non-condensing) | | |
| Operating Temperature | -20°C~60°C / -4°F~140°F | | |
| Storage Temperature | -40°C~85°C / -40°F~185°F | | |
| Power Supply | DC 12~48V, Redundant power and removable terminal block | | |
| Case | Metal case. IP-30 Protection | | |
| Dimension | 50 (W) x 95 (D) x 140 (H) mm | | |
| Weight | 440 g | | |
| Installation | DIN Rail and Wall Mount Design | | |
| Warranty | 5 years | | |