

Lantech

IPES/IES-5216DF Series

16 10/100TX + 2 100/1000FX Dual Speed Fiber L2+ (8 PoE at/af)
Industrial Managed Switch w/ITU G.8032 Ring

User Manual (Hardware)



IP-67



IP-43

Dec. 2015

Recommendation for Shielded network cables

STP cables have additional shielding material that is used to reduce external interference. The shield also reduces the emission at any point in the path of the cable. Our recommendation is to deploy an STP network cable in demanding electrical environments. Examples of demanding indoor environments are where the network cable is located in parallel with electrical mains supply cables or where large inductive loads such as motors or contactors are in close vicinity to the camera or its cable. It is also mandatory to use an STP cable where the power device (like IP camera) is used outdoors or where the network cable is routed outdoors.

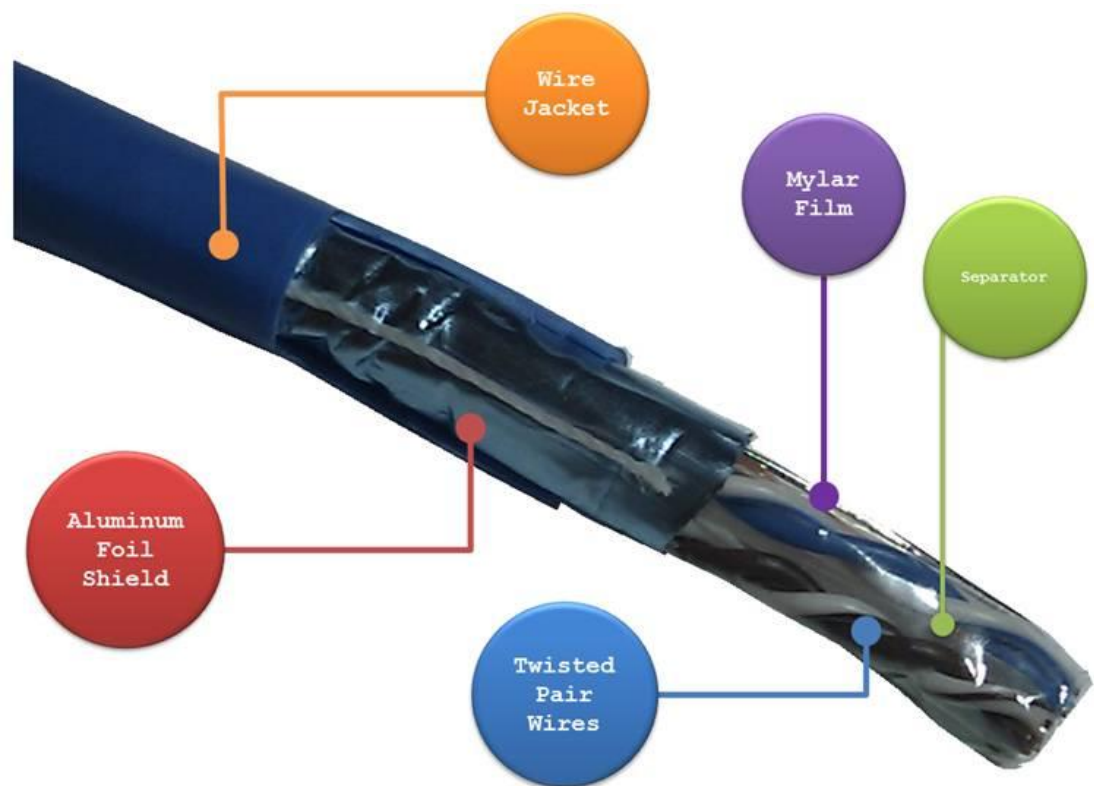

Important Notice

Lantech Communications Global, Inc. reserves the right to modify the equipment, its specification or this manual without prior notice, in the interest of improving performance, reliability, or servicing. At the time of publication all data is correct for the operation of the equipment at the voltage and/or temperature referred to. Performance *data* indicates typical values related to the particular product.

No part of this documentation or information supplied may be divulged to any third party without the express written consent of Lantech Communications Global Inc. Products offered may contain software which is proprietary to Lantech Communications Global Inc. The offer or supply of these products and services does not include or infer any transfer of ownership.

Interference Issues

This Equipment has been tested and found to comply with the limits for a Class A digital device, pursuant to Part 15 of the FCC rules. These limits are designed to provide reasonable protection against harmful interference in a commercial or industrial installation. This equipment generates, uses, and can radiate radio frequency energy. It may cause harmful interference to radio communications if the equipment is not installed and used in accordance with the instructions.

FCC Warning

This Equipment has been tested and found to comply with the limits for a Class-A digital device, pursuant to Part 15 of the FCC rules. These limits are designed to provide reasonable protection against harmful interference in a residential installation. This equipment generates, uses, and can radiate radio frequency energy. It may cause harmful interference to radio communications if the equipment is not installed and used in accordance with the instructions. However, there is no guarantee that interference will not occur in a particular installation. If this equipment does cause harmful interference to radio or television reception, which can be determined by turning the equipment off and on, the user is encouraged to try to correct the interference by one or more of the following measures:

- Reorient or relocate the receiving antenna.
- Increase the separation between the equipment and receiver.
- Connect the equipment into an outlet on a circuit different from that to which the receiver is connected.
- Consult the dealer or an experienced radio/TV technician for help.

CE Mark Warning

This is a Class-A product. In a domestic environment this product may cause radio interference in which case the user may be required to take adequate measures.

Content

Chapter 1 Introduction.....	5
Specification.....	5
Chapter 2 Hardware Description	12
2.1 Physical Dimension.....	12
2.2 IP Protection.....	14
2.3 LED Indicators.....	17
Chapter 3 Hardware Installation	19
Chapter 4 Network Application.....	24
4.1 ITU G.8032 Scheme.....	24
4.2 Ring Coupling.....	24
4.3 Multiple Rings.....	25
4.4 Dual Homing.....	26
4.5 Chain	26
Chapter 5 Console Management	28
5.1 Connecting to the Console Port	28
5.2 Login in the Console Interface	28

Chapter 1 Introduction

Lantech IPES-5216DF-8 (IP67/IP43) is a high performance L2+ (Gigabit uplink) switch with 16 10/100TX + 2 Dual Speed Fiber w/8 PoE 802.3af/at Injectors by M12 provides L2 wire speed and advanced security function for network aggregation deployment.

Specification

IES-5216DF series

Standards	IEEE 802.3 10Base-T Ethernet IEEE 802.3u 100Base-TX IEEE802.3z Gigabit fiber IEEE802.3x Flow Control and Back Pressure IEEE802.3ad Port trunk with LACP IEEE802.1d Spanning Tree IEEE802.1w Rapid Spanning Tree IEEE802.1s Multiple Spanning Tree IEEE 802.3ad Link Aggregation Control Protocol (LACP) IEEE 802.1AB Link Layer Discovery Protocol (LLDP) IEEE 802.1X User Authentication (Radius) IEEE802.1p Class of Service IEEE802.1Q VLAN Tag
Switch Architecture	Back-plane (Switching Fabric): 7.2Gbps Packet throughput ability (Full-Duplex): 23.8Mpps @64bytes
Transfer Rate	14,880pps for Ethernet port 148,800pps for Fast Ethernet port 1,488,000pps for Gigabit Fiber Ethernet port
CPU	Marvell 800Mhz
RAM	256M Byte
Flash	128M Byte
Mac Address	16K MAC address table

Jumbo frame	10KB on all ports
Connectors	<p>10/100TX: 16 x ports M12 4-pole D-coded with Auto MDI/MDI-X function</p> <p>100/1000 Dual Speed Fiber: 2 x LC connector for single-mode or multi-mode type fiber cable</p> <p>RS-232 connector: 1 x M12 5-pole A-coded</p> <p>Power Input connector : 1 x M12 5-pole A-coded</p> <p>Relay contact : 1 x M12 5-pole A-coded</p>
Network Cable	<p>10Base-T: 2-pair UTP/STP Cat. 3, 4, 5/ 5E/ 6 cable EIA/TIA-568 100-ohm (100m)</p> <p>100Base-TX: 2-pair UTP/STP Cat. 5/ 5E/ 6 cable EIA/TIA-568 100-ohm (100m)</p> <p>1000Base-TX: 2-pair UTP/STP Cat. 5/ 5E/ 6 cable EIA/TIA-568 100-ohm (100m)</p>
Giga Optical Cable	<p>Multi-mode: 50/125um~62.5/125um</p> <p>Single mode: 9/125um</p> <p>Available distance: 0.5km (Multi-mode)/10km (Single-mode)</p> <p>Wavelength: 850nm (Multi-mode)/1310nm (Single-mode)</p>
100M Optical Cable	<p>Multi-mode: 50/125um~62.5/125um</p> <p>Single mode: 9/125um</p> <p>Available distance: 2km (Multi-mode)/30km (Single-mode)</p> <p>Wavelength: 850nm (Multi-mode)/1310nm (Single-mode)</p>
Bypass Protection**	<p>High-speed optical switching (<20ms)</p> <p>Minimal insertion loss (Max 1.6dB as Bypass Mode)</p>
Protocol	CSMA/CD
LED	<p>Per unit: Power 1 (Green), Power 2 (Green), P-Fail (Red)</p> <p>Ethernet port: Link/Activity (Green), Speed (Green);</p> <p>Optical fiber: Link/Activity (Green)</p>

DI/DO	1 Digital Input (DI) : Level 0: -30~2V / Level 1: 10~30V Max. input current:8mA 1 Digital Output(DO): Open collector to 40 VDC, 200mA
Operating Humidity	5% ~ 95% (Non-condensing)
Operating Temperature	-40°C~75°C / -40°F~167°F (72V model: -40°C~60°C / -40°F~140°F)
Storage Temperature	-40°C~85°C / -40°F~185°F
Power Supply	Standard model:9.5~60VDC dual input 72V model: 50.4~90VDC dual input 110V model : 43~137.5VDC dual input
Power Consumption	Max. 13W 12V~48VDC input Max. 16W 72VDC/110VDC input
Case Dimension	IP67 model: Aluminum case 285mm(W)x200mm(H)x84.4mm(D) IP43 model: Aluminum case 273mm(W)x187mm(H)x84.4mm(D)
Weight	2.1kgs(IP67); 1.8kgs (IP43)
Installation	DIN Rail** and Wall Mount Design
EMI & EMS	FCC Class A, CE EN55022 Class A, CE EN55024, CE EN61000-4-2, CE EN61000-4-3, CE EN61000-4-4, CE EN61000-4-5, CE EN61000-4-6, CE N61000-4-8, EN61000-4-11
Stability Testing	IEC60068-2-32 (Free fall), EN61373 (Shock and Vibration)
MTBF	NA
Verifications& report	EN50155/EN50121-3-2/EN50121-4 verification EN45545-2 R24/R25 (EN ISO 4589-2, EN ISO 5659-2, NF X70-100-1 & 2) Fire & Smoke verification
Warranty	5 years

*Future release

**Optional

IPES-5216DFT-8 series

Standards	<p>IEEE 802.3 10Base-T Ethernet</p> <p>IEEE 802.3u 100Base-TX</p> <p>IEEE802.3z Gigabit fiber</p> <p>IEEE802.3x Flow Control and Back Pressure</p> <p>IEEE802.3ad Port trunk with LACP</p> <p>IEEE802.1d Spanning Tree</p> <p>IEEE802.1w Rapid Spanning Tree</p> <p>IEEE802.1s Multiple Spanning Tree</p> <p>IEEE 802.3ad Link Aggregation Control Protocol (LACP)</p> <p>IEEE 802.1AB Link Layer Discovery Protocol (LLDP)</p> <p>IEEE 802.1X User Authentication (Radius)</p> <p>IEEE802.1p Class of Service</p> <p>IEEE802.1Q VLAN Tag</p> <p>IEEE802.3at/af Power over Ethernet</p>
Switch Architecture	<p>Back-plane (Switching Fabric): 7.2Gbps</p> <p>Packet throughput ability (Full-Duplex): 23.8Mpps @64bytes</p>
Transfer Rate	<p>14,880pps for Ethernet port</p> <p>148,800pps for Fast Ethernet port</p> <p>1,488,000pps for Gigabit Fiber Ethernet port</p>
CPU	Marvell 800Mhz
RAM	256M Byte
Flash	128M Byte
Mac Address	16K MAC address table
Jumbo frame	10KB on all ports
Connectors	<p>10/100TX: 16 x ports M12 4-pole D-coded with Auto MDI/MDI-X function</p> <p>100/1000 Dual Speed Fiber: 2 x LC connector for single-mode or multi-mode type fiber cable</p> <p>RS-232 connector: 1 x M12 5-pole A-coded</p> <p>Power Input connector : 1 x M2 5-pole A-coded</p> <p>Relay contact : 1 x M12 5-pole A-coded</p>

Network Cable	<p>10Base-T: 2-pair UTP/STP Cat. 3, 4, 5/ 5E/ 6 cable EIA/TIA-568 100-ohm (100m)</p> <p>100Base-TX: 2-pair UTP/STP Cat. 5/ 5E/ 6 cable EIA/TIA-568 100-ohm (100m)</p> <p>1000Base-TX: 2-pair UTP/STP Cat. 5/ 5E/ 6 cable EIA/TIA-568 100-ohm (100m)</p>
Giga Optical Cable	<p>Multi-mode: 50/125um~62.5/125um Single mode: 9/125um Available distance: 0.5km (Multi-mode)/10km (Single-mode) Wavelength: 1310nm (Multi-mode/Single-mode)</p>
100M Optical Cable	<p>Multi-mode: 50/125um~62.5/125um Single mode: 9/125um Available distance: 2km (Multi-mode)/30km (Single-mode) Wavelength: 1310nm (Multi-mode/Single-mode)</p>
Bypass Protection**	<p>High-speed optical switching (<20ms) Minimal insertion loss (Max 1.6dB as Bypass Mode)</p>
Protocol	CSMA/CD
LED	<p>Per unit: Power 1 (Green), Power 2 (Green), P-Fail (Red) Ethernet port: Link/Activity (Green), Speed (Green); Optical fiber: Link/Activity (Green)</p>
DI/DO	<p>1 Digital Input (DI) : Level 0: -30~2V / Level 1: 10~30V Max. input current:8mA 1 Digital Output(DO): Open collector to 40 VDC, 200mA</p>
Operating Humidity	5% ~ 95% (Non-condensing)
Operating Temperature	-40°C~75°C / -40°F~167°F (72V model: -40°C~60°C / -40°F~140°F)
Storage Temperature	-40°C~85°C / -40°F~185°F
Power Supply	<p>Standard model: 45~56VDC dual input 12V model: 9.5~56VDC dual input 72V model: 50.4~90VDC dual input</p>

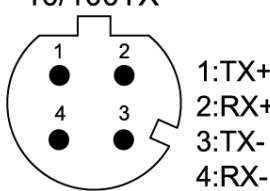
	110V model: 43~137.5VDC dual input
PoE Budget	240W for 45~56V input (55V input is recommended for 802.3at 30W applications) 80W for 12V input 120W for 24V input 80W for 72V Input 80W for 110V Input
PoE pin assignment	M12 port # 1~#8 support IEEE 802.3at/af End-point, Alternative A mode. Per port provides 30W PoE at/ 15W PoE af. <div style="text-align: center;"> <p>10/100TX</p>  <p>1:TX+ 2:RX+ 3:TX- 4:RX-</p> </div>
Power Consumption	Max. 13W 12V~48VDC input Max. 16W 72VDC/110VDC input
Case Dimension	IP67 model: Aluminum case 285mm(W)x200mm(H)x84.4mm(D) IP43 model: Aluminum case 273mm(W)x187mm(H)x84.4mm(D)
Weight	2.1kgs(IP67); 1.8kgs (IP43)
Installation	DIN Rail** and Wall Mount Design
EMI & EMS	FCC Class A, CE EN55022 Class A, CE EN55024, CE EN61000-4-2, CE EN61000-4-3, CE EN61000-4-4, CE EN61000-4-5, CE EN61000-4-6, CE N61000-4-8, EN61000-4-11
Stability Testing	IEC60068-2-32 (Free fall), EN61373 (Shock and Vibration)
MTBF	NA
Verifications& report	EN50155/EN50121-3-2/EN50121-4 verification EN45545-2 R24R25 (EN ISO 4589-2, EN ISO 5659-2, NF X70-100-1 & 2) Fire & Smoke verification
Warranty	5 years

*Future release

**Optional

Chapter 2 Hardware Description

In this paragraph, it will describe the Industrial switch's hardware spec, port, cabling information, and wiring installation.

2.1 Physical Dimension

Aluminum case. IP-67,
285 (W) x 201.4 (D) x 84.4 (H) mm

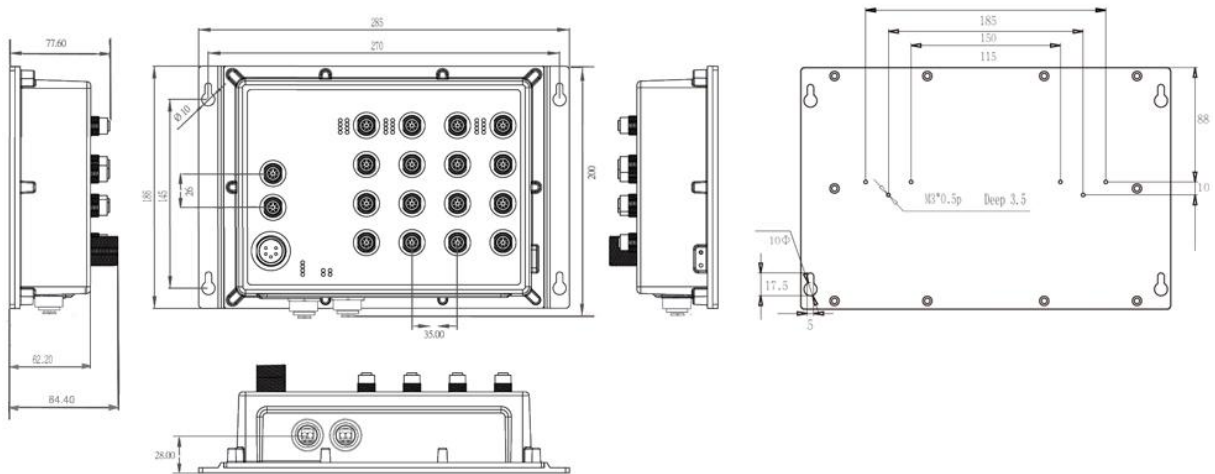

Port description of IP-67 series switch

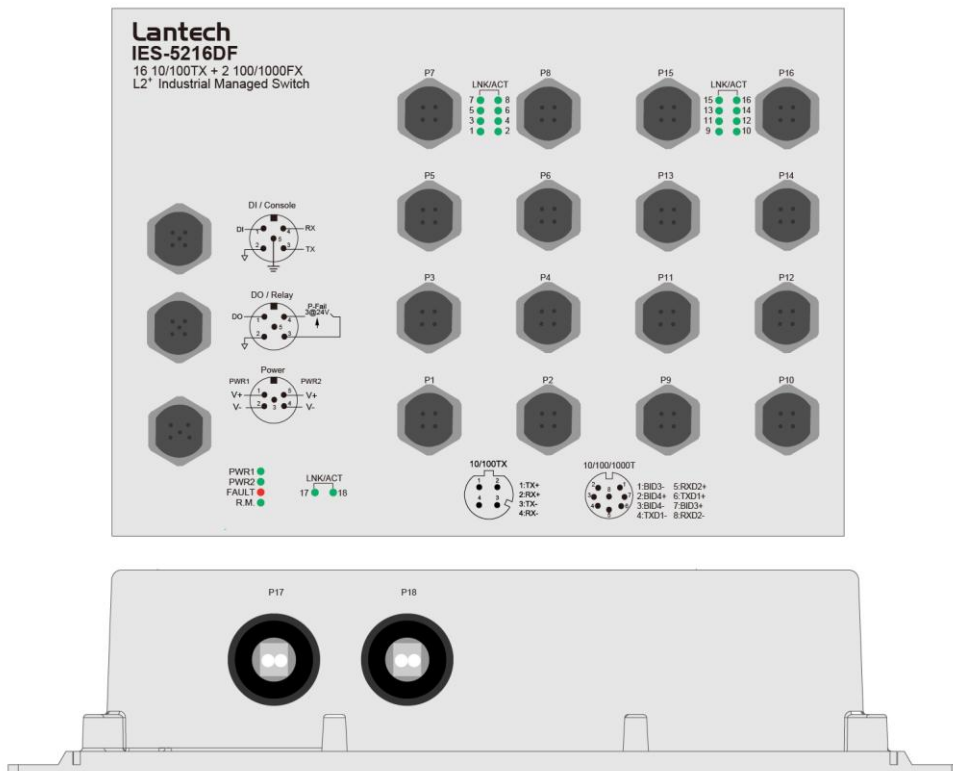

Aluminum case. IP-43,
273 (W) x 188.4(D) x 84.4 (H) mm

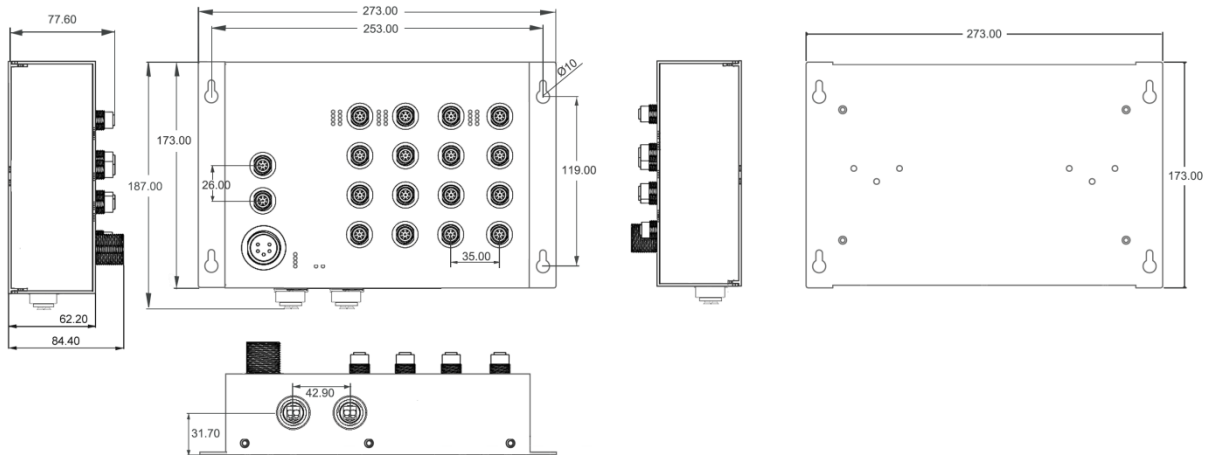

****The description of interface of IP-43 model is the same as IP-67 series.**

2.2 Package Content:

- Manual CD X1
- Industrial Switch X1
- Console cable X1

2.3 IP Protection

The **IP Code, Ingress Protection Rating**, sometimes also interpreted as **International Protection Rating**, classifies and rates the degree of protection provided against the intrusion (including body parts such as hands and fingers), dust, accidental contact, and water in *mechanical casings* and with electrical enclosures. It is published by the International Electrotechnical Commission (IEC)

Solid particle protection

The first digit indicates the level of protection that the enclosure provides against access to hazardous parts (e.g., electrical conductors, moving parts) and the ingress of solid foreign objects.

Level	Object size protected against	Effective against
0	—	No protection against contact and ingress of objects
1	>50 mm	Any large surface of the body, such as the back of a hand, but no protection against deliberate contact with a body part
2	>12.5 mm	Fingers or similar objects
3	>2.5 mm	Tools, thick wires, etc.
4	>1 mm	Most wires, screws, etc.
5	Dust protected	Ingress of dust is not entirely prevented, but it must not enter in sufficient quantity to interfere with the satisfactory operation of the equipment; complete protection against contact
6	Dust tight	No ingress of dust; complete protection against contact

Liquid ingress protection

The second digit indicates the level of protection that the enclosure provides against harmful ingress of water.

Level	Protected against	Testing for	Details
0	Not protected	—	—
1	Dripping water	Dripping water (vertically falling drops) shall have no harmful effect.	Test duration: 10 minutes Water equivalent to 1 mm rainfall per minute
2	Dripping water when tilted up to 15°	Vertically dripping water shall have no harmful effect when the enclosure is tilted at an angle up to 15° from its normal position.	Test duration: 10 minutes Water equivalent to 3 mm rainfall per minute
3	Spraying water	Water falling as a spray at any angle up to 60° from the vertical shall have no harmful effect.	Test duration: 5 minutes Water volume: 0.7 litres per minute Pressure: 80–100 kPa
4	Splashing of water	Water splashing against the enclosure from any direction shall have no harmful effect.	Test duration: 5 minutes Water volume: 10 litres per minute Pressure: 80–100 kPa
5	Water jets	Water projected by a nozzle (6.3 mm) against enclosure from any direction shall have no harmful effects.	Test duration: at least 15 minutes Water volume: 12.5 litres per minute Pressure: 30 kPa at distance of 3 m

6	Powerful water jets	Water projected in powerful jets (12.5 mm nozzle) against the enclosure from any direction shall have no harmful effects.	Test duration: at least 3 minutes Water volume: 100 litres per minute Pressure: 100 kPa at distance of 3 m
7	Immersion up to 1 m	Ingress of water in harmful quantity shall not be possible when the enclosure is immersed in water under defined conditions of pressure and time (up to 1 m of submersion).	Test duration: 30 minutes Immersion at depth of at least 1 m measured at bottom of device, and at least 15 cm measured at top of device
8	Immersion beyond 1 m	The equipment is suitable for continuous immersion in water under conditions which shall be specified by the manufacturer. Normally, this will mean that the equipment is hermetically sealed. However, with certain types of equipment, it can mean that water can enter but only in such a manner that it produces no harmful effects.	Test duration: continuous immersion in water Depth specified by manufacturer
9	Powerful high temperature water jets	Protected against close-range high pressure, high temperature spray downs.	—

2.4 LED Indicators

The diagnostic LEDs that provide real-time information of system and optional status are located on the front panel of the industrial switch. The following table provides the description of the LED status and their meanings for the switch.

LED	Color	Status	Meaning
R.M	Green	On	The switch unit is owner switch of ITU-Ring
		Off	The switch is not owner switch
PWR1	Green	On	Power 1 is active
		Off	Power 1 is inactive
PWR2	Green	On	Power 2 is active
		Off	Power 2 is inactive
FAULT	Red	On	Power or port failure
		Off	No failure
P1 ~ P16	Link/Ack	On	A network device is detected.
		Blinking	The port is transmitting or receiving packets from the TX device.
		Off	No device attached
	PoE(1~8)	On	The port is operating in PoE mode.(IPES)
Off		The port is not operating in PoE mode.(IPES)	
P17 ~ P18	Link/Ack	On	A network device is detected.
		Blinking	The port is transmitting or receiving packets from the TX device.

		Off	No device attached.
--	--	-----	---------------------

Chapter 3 Hardware Installation

3.1 Hardware installation

3.1.1 Unpack switch and check the accessory with packing list

3.1.2 Mount the switch on desired position

3.1.3 Connect the M23/M12 connector of power input.

■ Voltage of Power Input

Non-PoE model (5-pin M12 connector)	Standard model: The power input voltage can be from 9.5V to 60VDC
	72V model: The power input voltage can be from 50.4V to 90VDC
	110V model: The power input voltage can be from 43V to 137.5VDC
PoE model (5-pin M23 connector)	Standard model: The voltage of power input should use 48VDC to feed power IEEE 802.3af standardized devices or 54VDC for IEEE 802.3at standardized ones.
	12V model: The power input voltage can be from 9.5V to 56VDC to feed power on both the 802.3af and 802.3at standardized devices.

	<p>72V model:</p> <p>The power input voltage can be from 50.4V to 90VDC to feed power on both 802.3af/at standardized devices.</p>
	<p>110V model:</p> <p>The power input voltage can be from 43V to 137.5VDC to feed power on both 802.3af/at standardized devices.</p>

Make sure that the external power supply unit you use to provide the PoE voltage fulfils the following basic criteria:

- The output voltage of power supply must exceed 48VDC for 802.3af and 53VDC for 802.3at operation (*with IPES-5216DF-8-72V, only 72VDC can power both the 802.3af and 802.3at PD. **with IPES-5216DF-8-110V, only 110VDC can power both the 802.3af and 802.3at PD.)
- The power consumption can satisfy the total power request from all PD devices required.

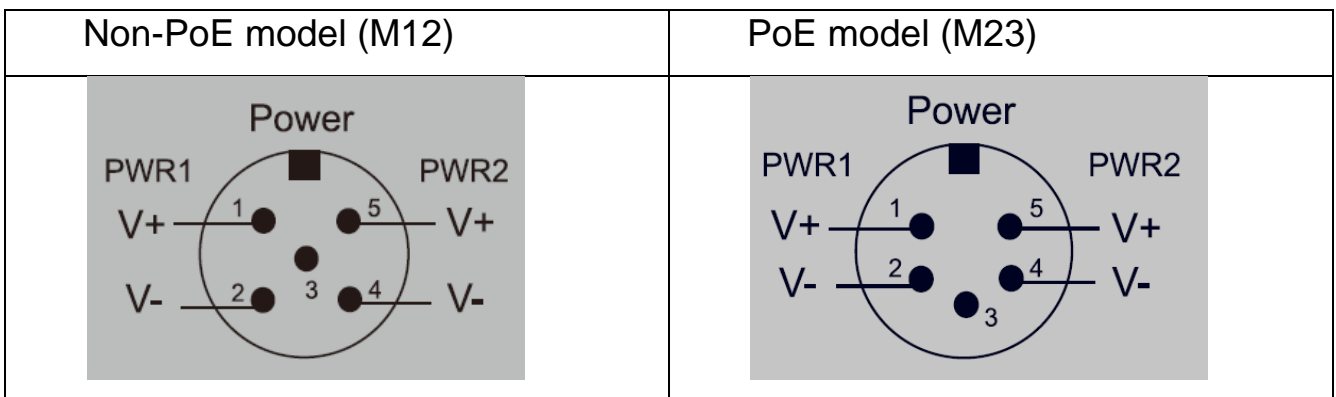

Pin assignment of Power input

■ Dual Power Input

The power input can be supported redundantly. The supply voltage is

electrically isolated from the housing.

Note: With single power supply of the mains voltage, the device will report a power failure. You can disable this power fail event via web browser.

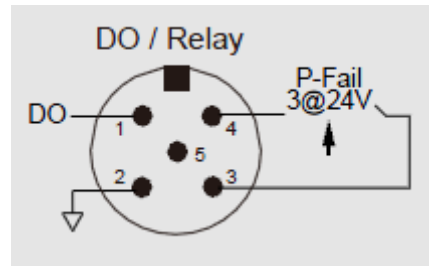

Pin assignment of alarm relay

A break in contact is reported via the relay contact :

- The failure of at least one of the two supply voltages.
- The break link status of at least one switch port.

3.1.4 Fitting the device, grounding

Install the system in a dry and clean area to protect the switch to get exposed with dirt.

Plug the connector to the power supply plug then turn on the power supply.

■ Ground

The chassis is grounded via a separate ground nut (M3).

Use toothed locking washers for a good electrical connection.

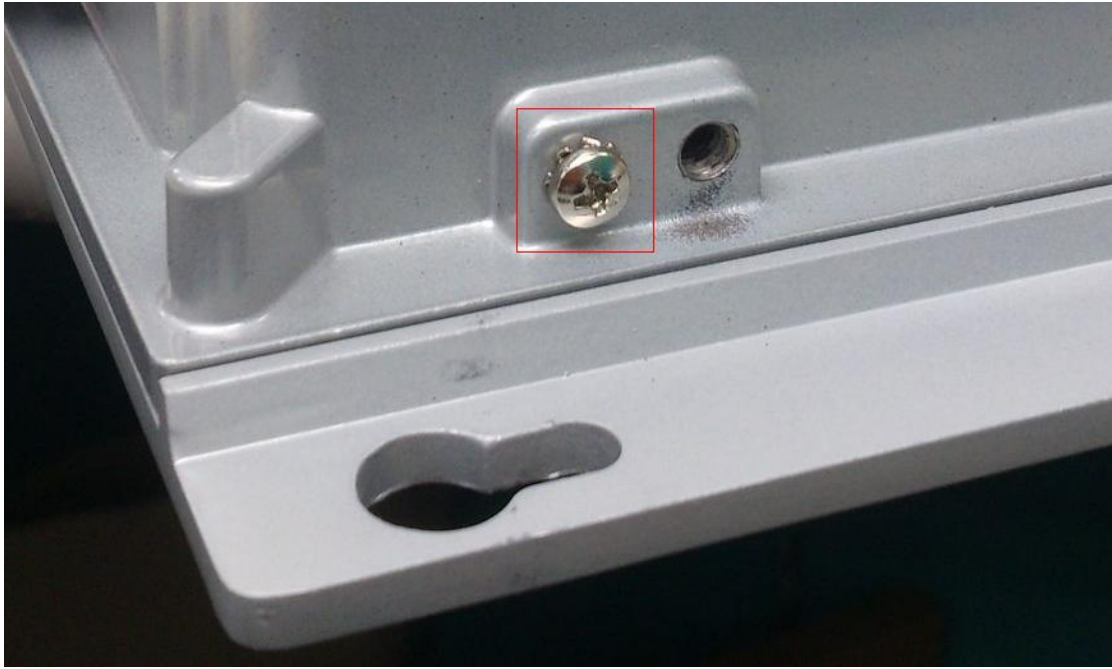

Ground screw of IPES-5408T switch

3.1.5 Connect the M12 connector with RJ-45 data cable, ports are not used shall be capped that comes with the package to insulate the surrounding.

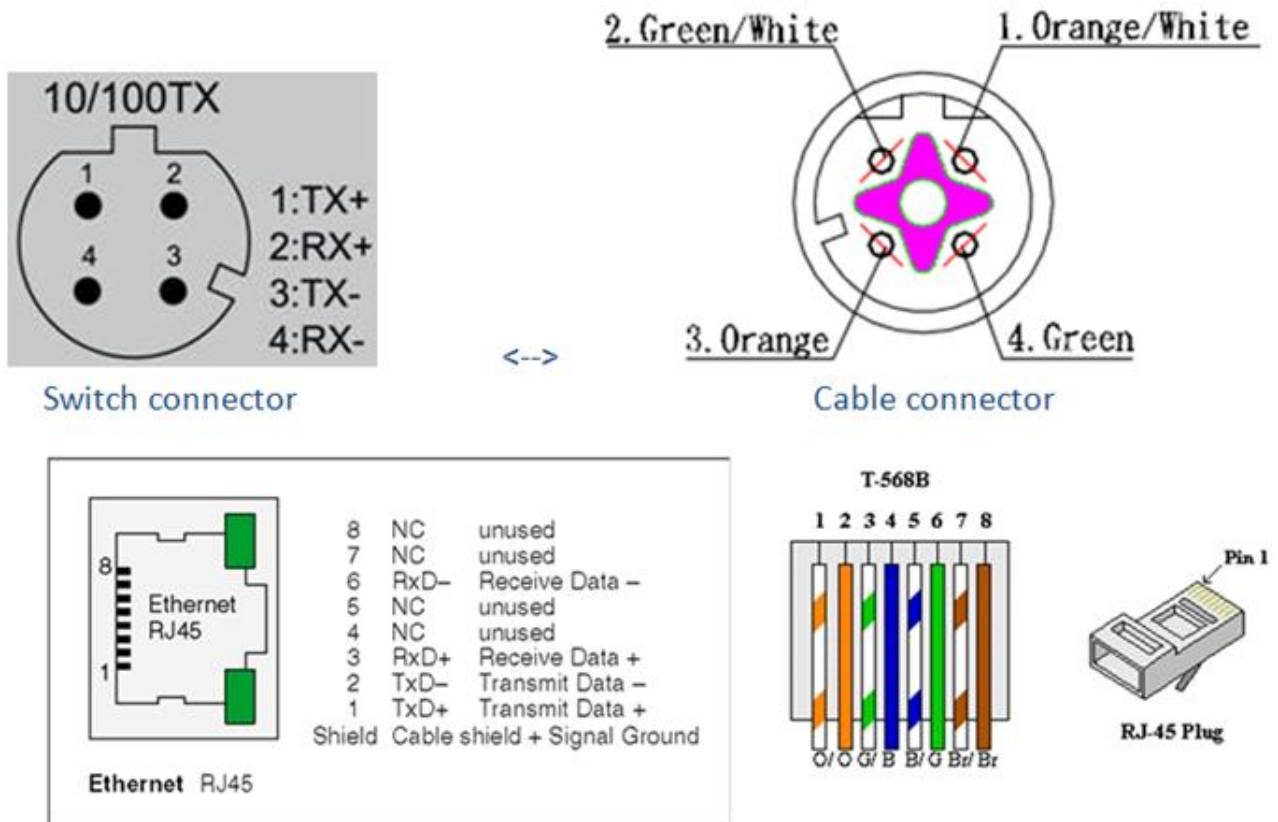

Pin assignment of M12 10/100Tx network connector

3.1.6 Check the status of LED, make sure the switch was in working status.

Note:

- The protection class IP67/IP43 is only achieved when bolted together.
- The other components attaching to the system have to meet with the IP67/IP43 protection class in order to reach the whole system IP 67/IP43 protection.
- Empty ports must be sealed with the protective caps supplied.

Chapter 4 Network Application

4.1 ITU G.8032 Scheme

LANTECH G.8032 protocol is following ITU (International Telecommunication Unit) G.8032 v2 draft. The benefits of G.8032 are:

1. <50ms recovery time when failover
2. G.8032 has defined the protocol scheme, parameters, functions, test measures to be unified that the users can evaluate the possible network infrastructure without literally testing each brand in large scale.

4.2 Ring Coupling

Redundant Coupling

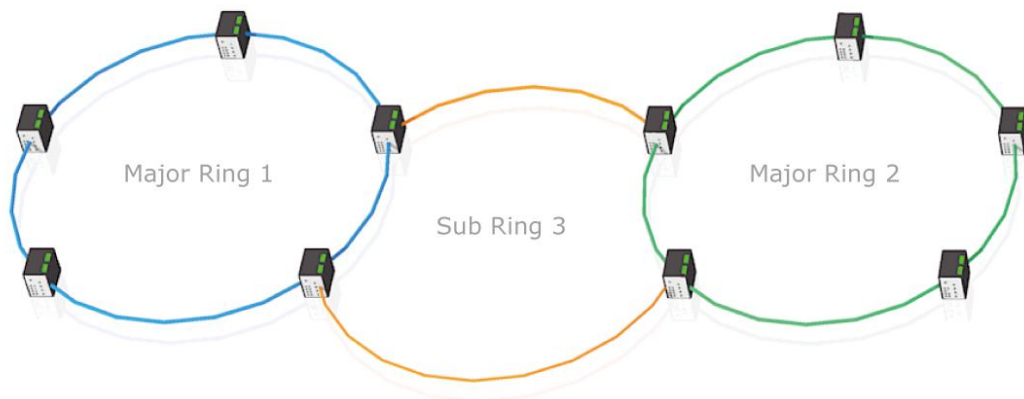

Redundant Coupling with Multiple Rings

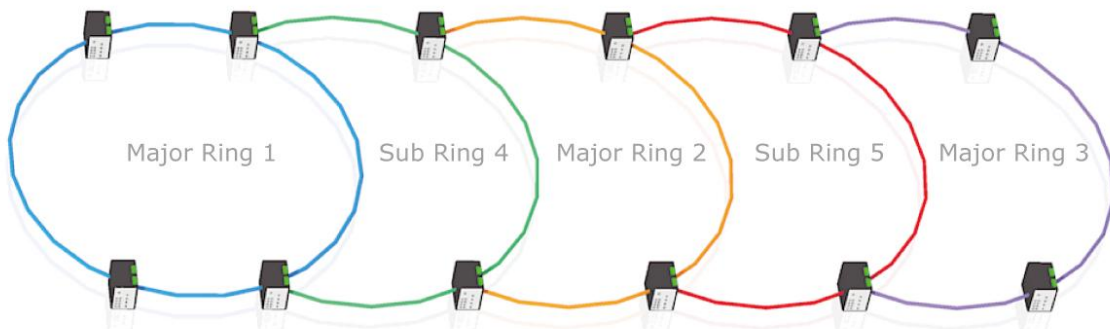

4.3 Multiple Rings

Dual Rings

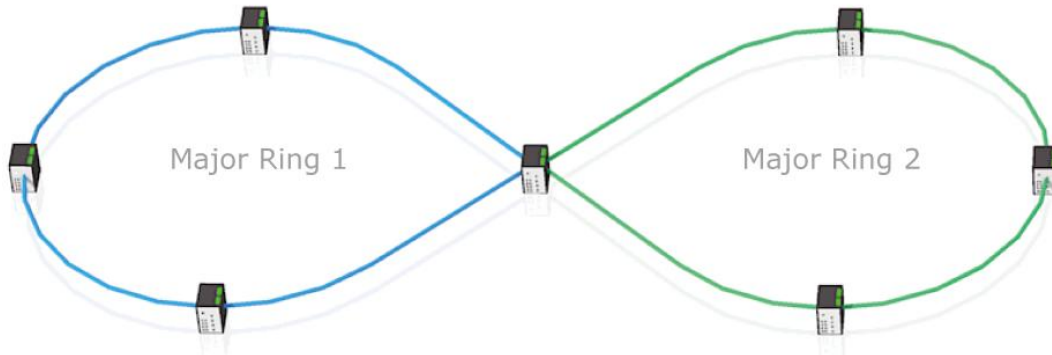

Multiple Rings

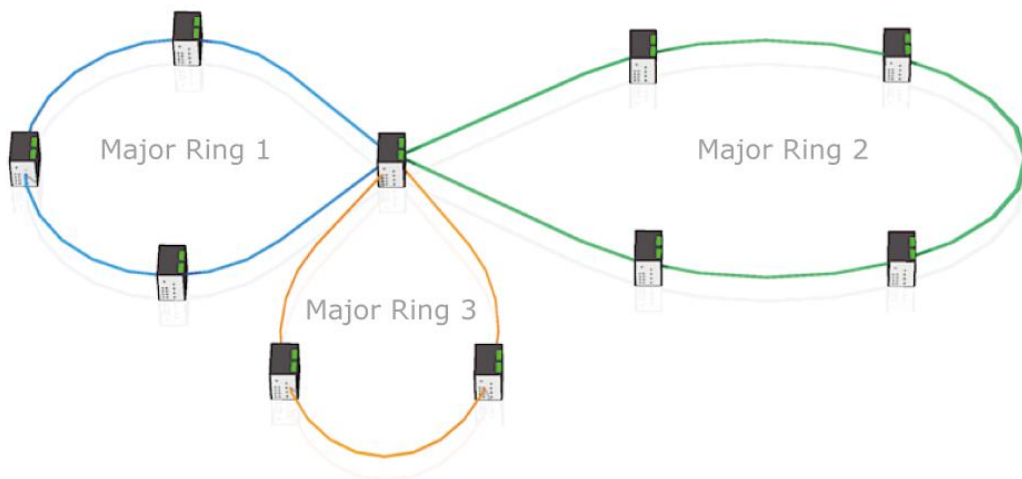

4.4 Dual Homing

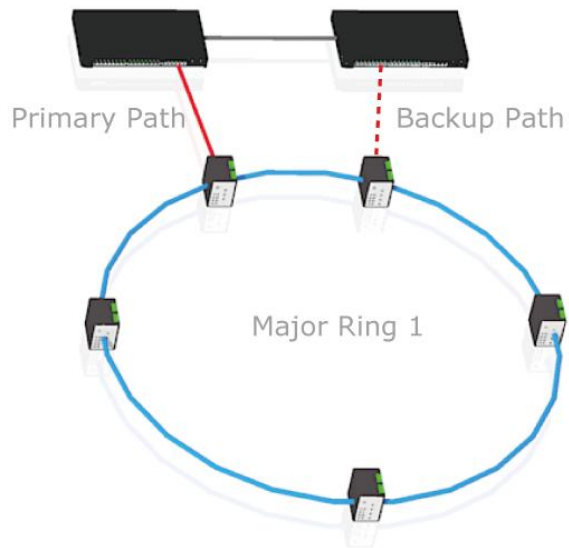

4.5 Chain

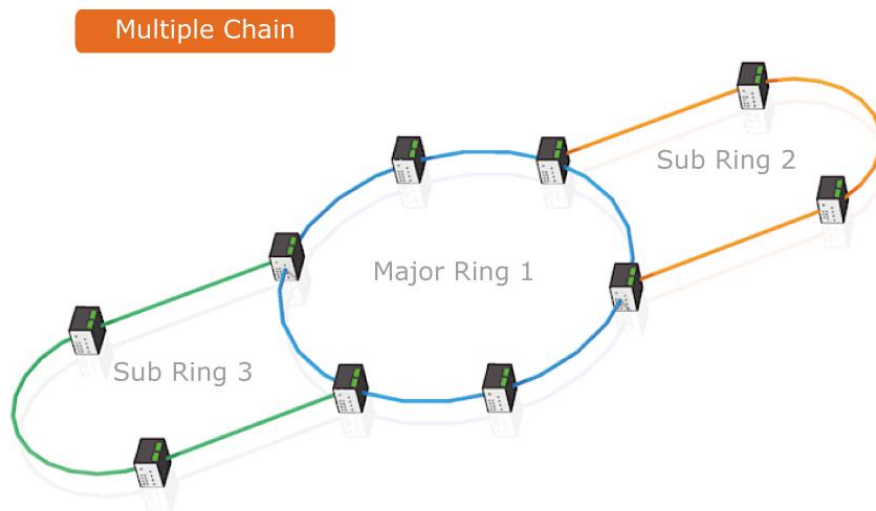

Multiple Chain Share Common Ends

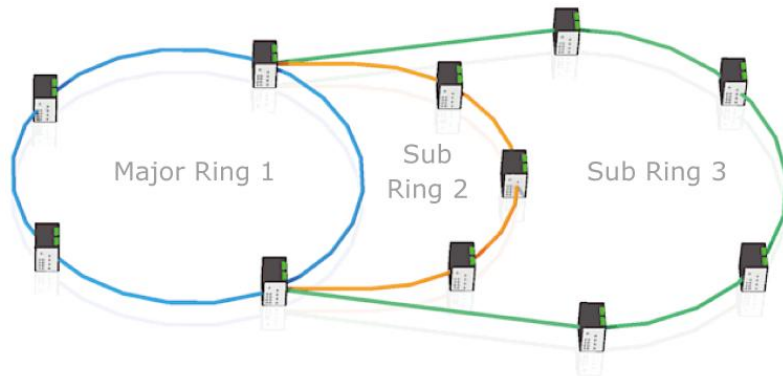

Cascade Chain

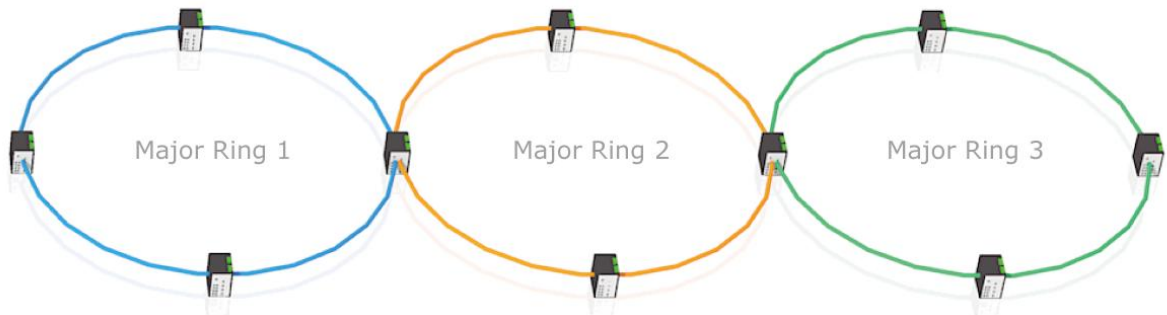

Chain in Chain

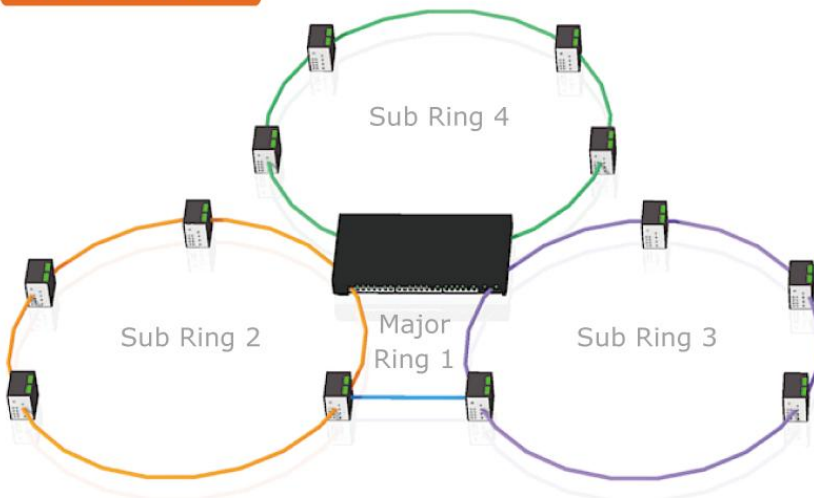

Chapter 5 Console Management

5.1 Connecting to the Console Port

The supplied cable which one end is M12 5-pole connector and the other end is RS-232 connector. Attach the end of RS-232 connector to PC or terminal and the other end of M12 connector to the console port of the switch. The connected terminal or PC must support the terminal emulation program.

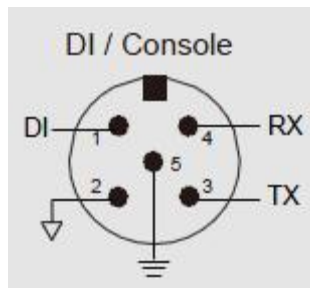

5.2 Login in the Console Interface

When the connection between Switch and PC is ready, turn on the PC and run a terminal emulation program or **Hyper Terminal** and configure its **communication parameters** to match the following default characteristics of the console port:

Baud Rate: 115200 bps

Data Bits: 8

Parity: none

Stop Bit: 1

Flow control: None

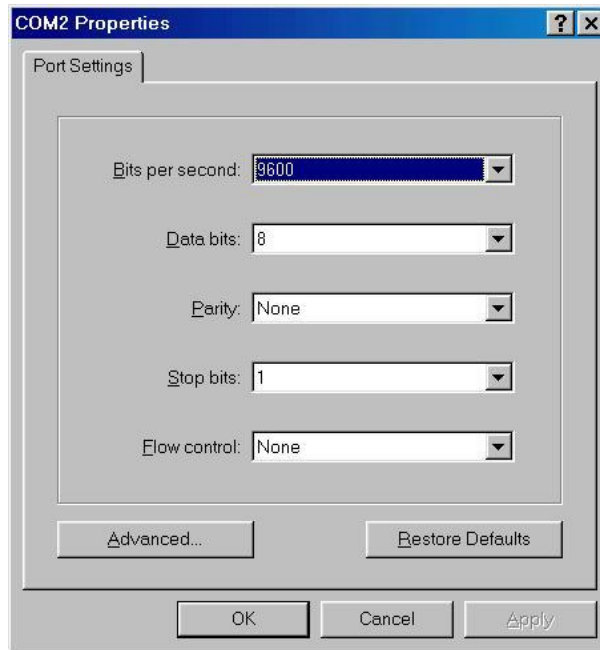

The settings of communication parameters

Having finished the parameter settings, click 'OK'. When the blank screen shows up, press Enter key to have the login prompt appears. Key in 'admin' (default value) for both User name and Password (use **Enter** key to switch), then press Enter and the Main Menu of console management appears. Please see below figure for login screen.



Console login interface

=====Notice=====

For web-based management, please refer to our "Software Management Manual" at <http://www.lantechcom.tw/global/eng/support-downloads.html>