

# Mini-GBIC (SFP)

## 10G Copper SFP+ Transceiver, 30M

- Distance: 30M
- Operating Temperature: 0°C ~ 70°C
- 1G/ 2.5G/ 5G/ 10GBase-T Application



## OVERVIEW

Lantech SFP-10GB-T Small Form Factor Pluggable SFP+ Copper transceivers are compliant with the current SFP+ Multi-Source Agreement (MSA) Specification. The high performance designed is integrated full duplex data link at 10Gbps over four pair Category 6a/7 cable up to 30m links. It is specifically designed for high speed communication links that require 10 Gigabit Ethernet over copper cable.

## FEATURES & BENEFITS

- Compliant with IEEE 802.3az, 802.3ab and 802.3 standard
- Compliant with SFP+ MSA (SFF-8431, SFF-8432)
- Support 10GBase-T/ 5GBase-T/ 2.5GBase-T/ 1000Base-T
- Hot Pluggable
- Auto-negotiates with other 10GBase-T PHYs
- Auto-detect MDI/MDI-X
- Support RX\_LOS function
- I2C 2-wire interface for serial ID and PHY register access
- RJ-45 connector
- Single +3.3V power supply
- 10G link length up to 30m with Cat.6a/7, 2.5G/5G link length up to 50m with Cat.5E, 1G link length up to 100m with Cat.5E
- RoHS Compliant

## SPECIFICATION

### Absolute Maximum Ratings

Parameter	Symbol	Min.	Max.	Unit	Note
Storage Temperature	T <sub>ST</sub>	-40	+85	°C	
Supply Voltage	V <sub>CC</sub> T, V <sub>CC</sub> R	-0.5	+4.0	V	
Storage Relative Humidity	RH	5	95	%	

### Recommended Operating Conditions

Parameter	Symbol	Min.	Typ.	Max.	Unit	Note
Case Operating Temperature	T <sub>OP</sub>	0	-	+70	°C	
Supply Voltage	V <sub>CC</sub>	+3.13	+3.3	+3.47	V	
Supply Current	I <sub>CC</sub>			880	mA	
Power Consumption @30M	P <sub>CO</sub>			2.9	W	

### General Specifications

Parameter	Symbol	Min.	Typ.	Max.	Unit	Note
Data Rate	DR	1	10.3125		GB/sec	

Bit Error Rate	BER			10 <sup>-12</sup>		
----------------	-----	--	--	-------------------	--	--

**High-Speed Electrical Interface, Host to SFP+**

V<sub>CC</sub>= 3.13V to 3.47V, T<sub>op</sub> = 0 °C to 70 °C

Parameters	Symbol	Min.	Typ.	Max.	Unit	Note
TD+, TD- Input Voltage Swing	V <sub>IN+</sub> / V <sub>IN-</sub>	250		1200	mV	1
RD+, RD- Output Voltage Swing	V <sub>out+</sub> / V <sub>out-</sub>	350		800	mV	1
Rise Time (Receiver)	T <sub>r</sub>		175		ps	2
Fall Time (Receiver)	T <sub>f</sub>		175		ps	2
Tx Input Impedance	Z <sub>in</sub>		50		Ohm	1
Rx Output Impedance	Z <sub>out</sub>		50		Ohm	1

**Note1:** Single ended

**Note2:** 20% to 80% value

**High-Speed Electrical Interface, Cable to SFP+**

V<sub>CC</sub>= 3.13V to 3.47V, T<sub>op</sub> = 0 °C to 70 °C

Parameters	Symbol	Min.	Typ.	Max.	Unit	Note
TX Output Impedance	Z <sub>out.TX</sub>		100		Ohm	1
RX Output Impedance	Z <sub>in.RX</sub>		100		Ohm	1

**Note1:** Differential for frequencies ranging from 125MHz to 10.3125GHz

**Pin Assignment:**

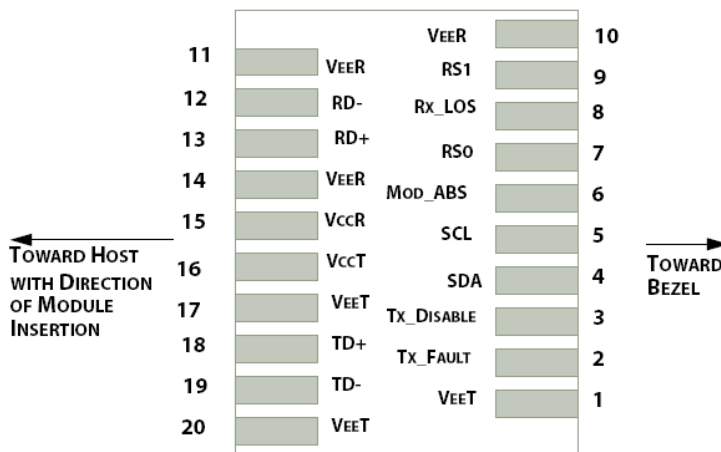

Host PCB SFP+ pad assignment top view

**Pin Descriptions:**

Pin	Name	Function / Description
1	VeeT	Transmitter Ground
2	TX_Fault	Transmitter Fault Indication (1)
3	TX_Disable	Transmitter Disable – Turns off transmitter laser output (2)
4	SDA	2-wire Serial Interface Data Line (SDA: Serial Data Signal) (3)
5	SCL	2-wire Serial Interface Clock (SCL: Serial Clock Signal) (3)
6	Mod_ABS	Module Absent, connected to VeeT or VeeR in the module (3)

7	RS0	Rate Select 0, optionally controls SFP+ module receiver (5)
8	Rx_LOS	Receiver Loss of Signal Indication (4)
9	RS1	Rate Select 1, optionally controls SFP+ module transmitter (5)
10	VeeR	Receiver Ground
11	VeeR	Receiver Ground
12	RD-	Receiver Inverted Data output, Differential LVPECL, AC coupled
13	RD+	Receiver Non-Inverted Data output, Differential LVPECL, AC coupled
14	VeeR	Receiver Ground
15	VccR	Receiver 3.3V Power Supply
16	VccT	Transmitter 3.3V Power Supply
17	VeeT	Transmitter Ground
18	TD+	Transmitter Non-Inverted Data Input, Differential LVPECL, AC coupled
19	TD-	Transmitter Inverted Data Input, Differential LVPECL, AC coupled
20	VeeT	Transmitter Ground

**Note1:** TX Fault is not used and is always tied to ground through a 100 ohm resistor.

**Note2:** TX Disable as described in the MSA is not applicable to the Copper-T module, but is used for convenience as an input to reset the internal PHY IC. This pin is pulled up within the module with a 4.7K $\Omega$  resistor.

Low (0 – 0.8 V): Transceiver on ;

Between (0.8 V and 2.0 V): Undefined

High (2.0 – 3.465 V): Transceiver in reset state

Open: Transceiver in reset state

**Note3:** These are the module definition pins. They should be pulled up with a 4.7K~10K $\Omega$  resistor on the host board to supply less than VccT+0.3V or VccR+0.3V. Mod-ABS is grounded by the module to indicate that the module is present.

**Note4:** LVTTTL compatible with a maximum voltage of 2.5V.

**Note5:** No connect on this module.

**DIMENSIONS (unit=mm)**

\*All dimensions are ±0.2mm unless otherwise specified

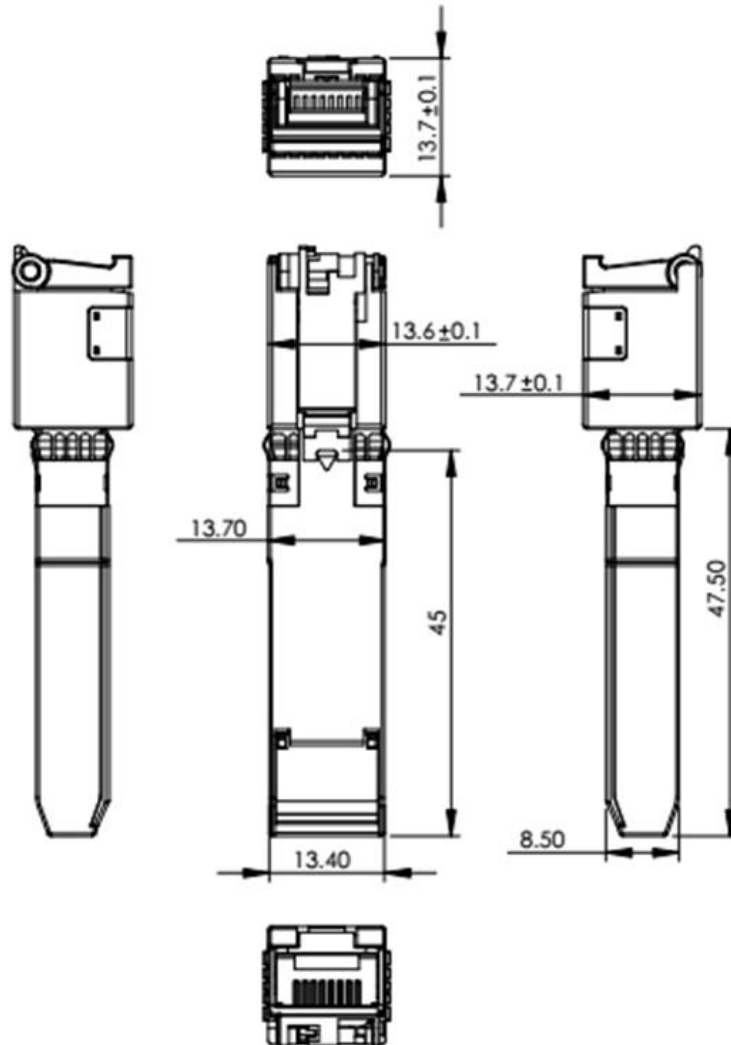

**ORDERING INFORMATION**

Part Number	Speed mode	Link	Temp.
8330-206	10GBase-T @Cat.6a/7 cable	30 meters	0~70°C
	5GBase-T/2.5GBase-T @Cat.5E cable	50 meters	
	1000Base-T @Cat.5E cable	100 meters	

**Lantech Communications Global Inc.**

www.lantechcom.tw  
info@lantechcom.tw

© 2019 Copyright Lantech Communications Global Inc. all rights reserved.  
The revise authority rights of product specifications belong to Lantech Communications Global Inc.  
Lantech may make changes to specification and product descriptions at anytime, without notice.