

Mini-GBIC (SFP)

1310nm DFB, Duplex LC, 2.5GBase-X SFP Transceiver

- Distance: 15km
- Standard Operating Temperature: -10°C ~ 70°C
- Wide Operating Temperature: -40°C ~ 85°C



OVERVIEW

Lantech 2.5GBase-X Small Form Factor Pluggable SFP transceivers are compliant with the current SFP Multi-Source Agreement (MSA) Specification. The high performance

1310nm DFB transmitter and high sensitive PIN receiver provide superior performance for SONET/SDH applications up to 15km optical links with single mode fiber.

FEATURES & BENEFITS

- Compliant with SONET OC-48 IR1 and SDH STM-16 S16.1 Standard
- Compliant with 2500Base-X
- Compliant with SFP MSA
- Compliant with SFP8472 diagnostic monitoring interface
- Hot Pluggable
- 1310nm DFB laser transmitter
- Duplex LC connector
- 2-wire interface for management and diagnostic monitor
- Single +3.3V power supply
- Transmission distance of 15km over single mode fiber
- RoHS Compliant

SPECIFICATION

Absolute Maximum Ratings

Parameter	Symbol	Min.	Max.	Unit	Note
Storage Temperature	T _{ST}	-40	+85	°C	
Supply Voltage	V _{CC}	-0.5	4.0	V	
Storage Relative Humidity	RH	5	95	%	

Recommended Operating Conditions

Parameter	Symbol	Min.	Typ.	Max.	Unit	Note
Case Operating Temperature (Standard model)	T _{OP}	-10		70	°C	
Case Operating Temperature (-E model)	T _{OP}	-40		85	°C	
Supply Voltage	V _{CC}	+3.15	+3.3	+3.45	V	
Supply Current	I _{CC}		200	260	mA	

Transmitter Electro-Optical Characteristics

V_{CC}=3.15V to 3.45V, T_{OP}= -10°C to 70°C (E model : -40°C to 85°C)

Parameter	Symbol	Min.	Typ.	Max.	Unit	Note
Optical launch Power	P _O	-5		0	dBm	1
Center Wavelength	λ _C	1280	1310	1340	nm	
Spectral Width (RMS)	Δλ			1	nm	
Side Mode Suppression Ratio	SMSR			30	dB	
Optical Extinction Ratio	ER	8.2			dB	
Rise/Fall Time (10%~90%)	T _r /T _f			0.16	ns	
Optical Eye Mask			ITU-T G.957 STM-16			
Differential Data Input Voltage	V _{DIFF}	300		1600	mV	
Transmit Disable Voltage	V _{DIS}	2.0		V _{CC}	V	
Transmit Enable Voltage	V _{EN}	GND		GND+0.8	V	

Notes: 1. The optical power is launched into a 9/125µm single-mode fiber.

Receiver Electro-Optical Characteristics

V_{CC}=3.15V to 3.45V, T_{OP}= -10°C to 70°C (E model : -40°C to 85°C)

Parameter	Symbol	Min.	Typ.	Max.	Unit	Note
Receiver Sensitivity	P _{IN} MIN			-18	dBm	1
Maximum Input Power	P _{IN} MAX	-3			dBm	1
Operating Center Wavelength	λ _c	1100		1610	nm	
LOS De-Assert	LOS _D			-18	dBm	
LOS Assert	LOS _A	-30			dBm	
LOS Hysteresis	LOS _{VHY}	0.5			dB	
Differential Data Output Voltage	V _{out, pp}	300		1000	mV	
Data Output Rise/Fall Time (10%~90%)	T _r /T _f			0.18	ns	
Receiver LOS Signal Output Voltage-Low	LOS _{V_L}	GND		GND+0.5	V	
Receiver LOS Signal Output Voltage-High	LOS _{V_H}	2.4		V _{cc}	V	

Notes: 1. Measured with a PRBS 2³¹-1 test pattern @ 2488Mbps BER <10⁻¹⁰

Pin Assignment

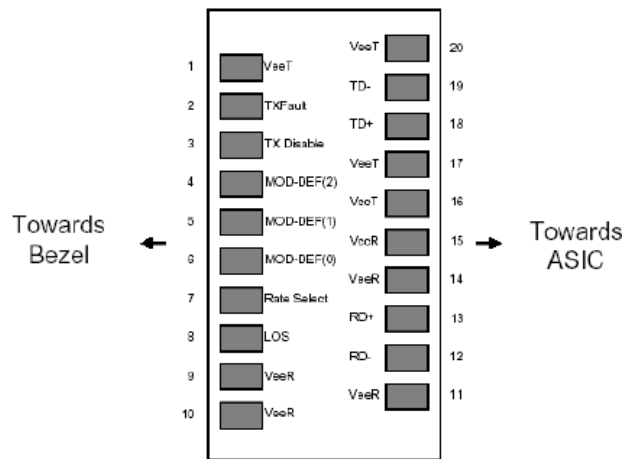

Diagram of Host Board Connector Block Pin Numbers and Name

Pin Description

Pin	Name	Function / Description
1	VeeT	Transmitter Ground
2	TX_Fault	Transmitter Fault Indication (1)
3	TX_Disable	Transmission Disable – Module disables on high or open (2)
4	MOD-DEF(2)	Module Definition 2 – SDA: Serial Data Signal
5	MOD-DEF(1)	Module Definition 1 – SCL: Serial Clock Signal
6	MOD-DEF(0)	Module Definition 0 – LVTTTL Low (3)
7	Rate Select	Not Connected – Open Circuit
8	LOS	Receiver Loss of Signal (4)
9	VeeR	Receiver Ground
10	VeeR	Receiver Ground
11	VeeR	Receiver Ground
12	RD-	Inverse Received Data out, Differential LVPECL, AC coupled
13	RD+	Received Data out, Differential LVPECL, AC coupled
14	VeeR	Receiver Ground
15	VccR	Receiver Power
16	VccT	Transmitter Power
17	VeeT	Transmitter Ground
18	TD+	Transmitter Data In, Differential LVPECL, AC coupled
19	TD-	Inverse Transmitter Data In, Differential LVPECL, AC coupled

20	VeeT	Transmitter Ground
----	------	--------------------

Note1: TX Fault is open collector/drain output which should be pulled up externally with a 4.7K~ 10KΩ resistor on the host board to supply $V_{ccT}+0.3V$ or $V_{ccR}+0.3V$. When high, this output indicates a laser fault of some kind. Low indicates normal operation. In the low state, the output will be pulled to <math><0.8V</math>.

Note2: TX Disable input is used to shut down the laser output per the state table below. It is pulled up within the module with a 4.7K~10KΩ resistor.

1)Low(0~0.8V): Transmitter on; 2)Between(0.8V and 2V): Undefined; 3)High (2.0~ VccT): Transmitter Disabled; 4)Open: Transmitter Disabled

Note3: Mod-DEF 0, 1, 2. These are the module definition pins. They should be pulled up with a 4.7K~10KΩ resistor on the host board to supply less than $V_{ccT}+0.3V$ or $V_{ccR}+0.3V$. Mod-DEF(0) is grounded by the module to indicate that the module is present. Mod-DEF(1) is clock line of two wire serial interface for optional serial ID. Mod-DEF(2) is data line of two wire serial interface for optional serial ID.

Note4: LOS (Loss of signal) is an open collector/drain output which should be pulled up externally with a 4.7K~10KΩ resistor on the host board to supply $V_{ccT}+0.3V$ or $V_{ccR}+0.3V$. When high, this output indicates the received optical power is below the worst case receiver sensitivity (as defined by the standard in use). Low indicates normal operation. In the low state, the output will be pulled to <math><0.8V</math>.

DIMENSIONS (unit=mm)

*All dimensions are ±0.2mm unless otherwise specified

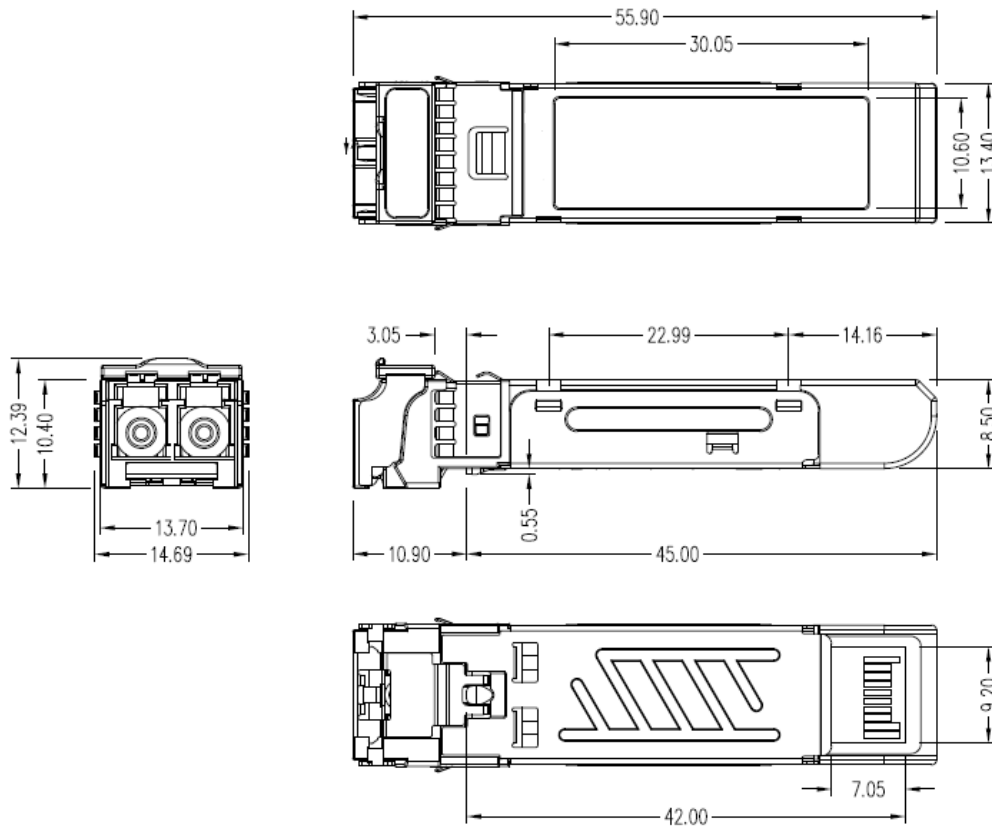

ORDERING INFORMATION

Part Number	TX	Link	Temp.
8330-265D	1310nm	15km	-10~70°C
8330-265D-E	1310nm	15km	-40~85°C

All SFP P/N# ended with D are with DDM function

Lantech Communications Global Inc.

www.lantechcom.tw
info@lantechcom.tw

© 2016 Copyright Lantech Communications Global Inc. all rights reserved.
The revise authority rights of product specifications belong to Lantech Communications Global Inc.
Lantech may make changes to specification and product descriptions at anytime, without notice.